



CEILING  
LIGHTING  
AMBIENCE



## DUR-SOLO TYPE 1

RAFT CEILING

[durlum.us](http://durlum.us)



Your contact for  
North America

**Formglas**

PRODUCT DATA SHEET

**DUR-SOLO TYPE 1**

RAFT CEILING

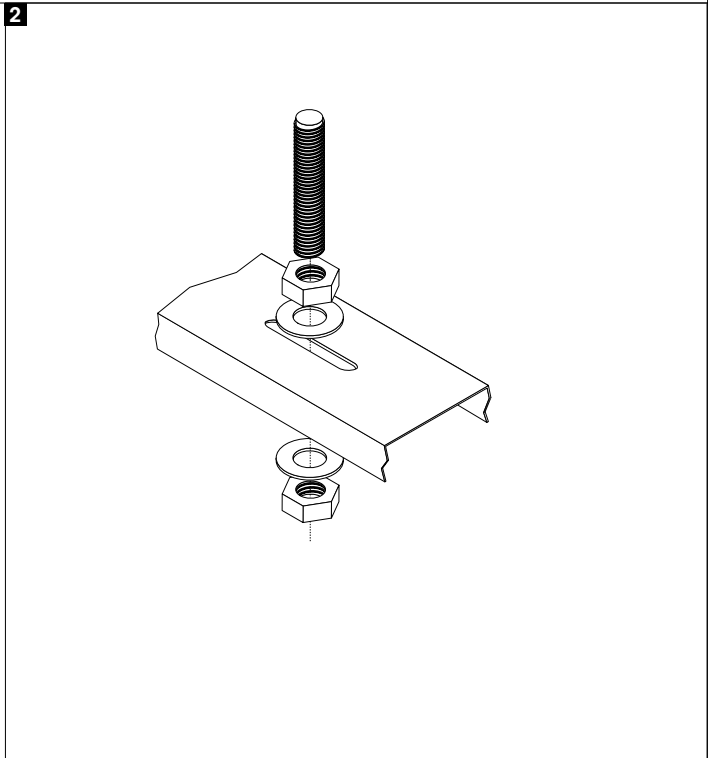
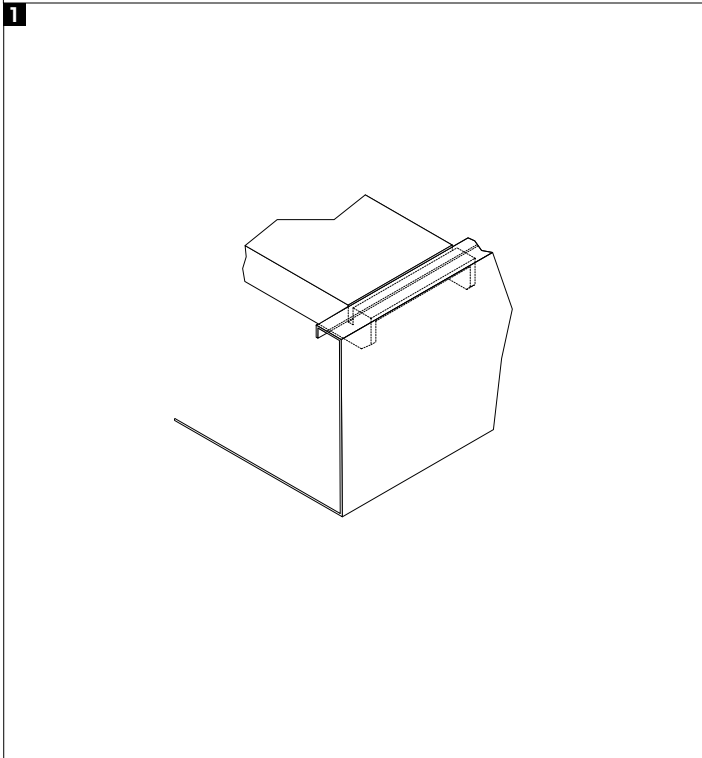
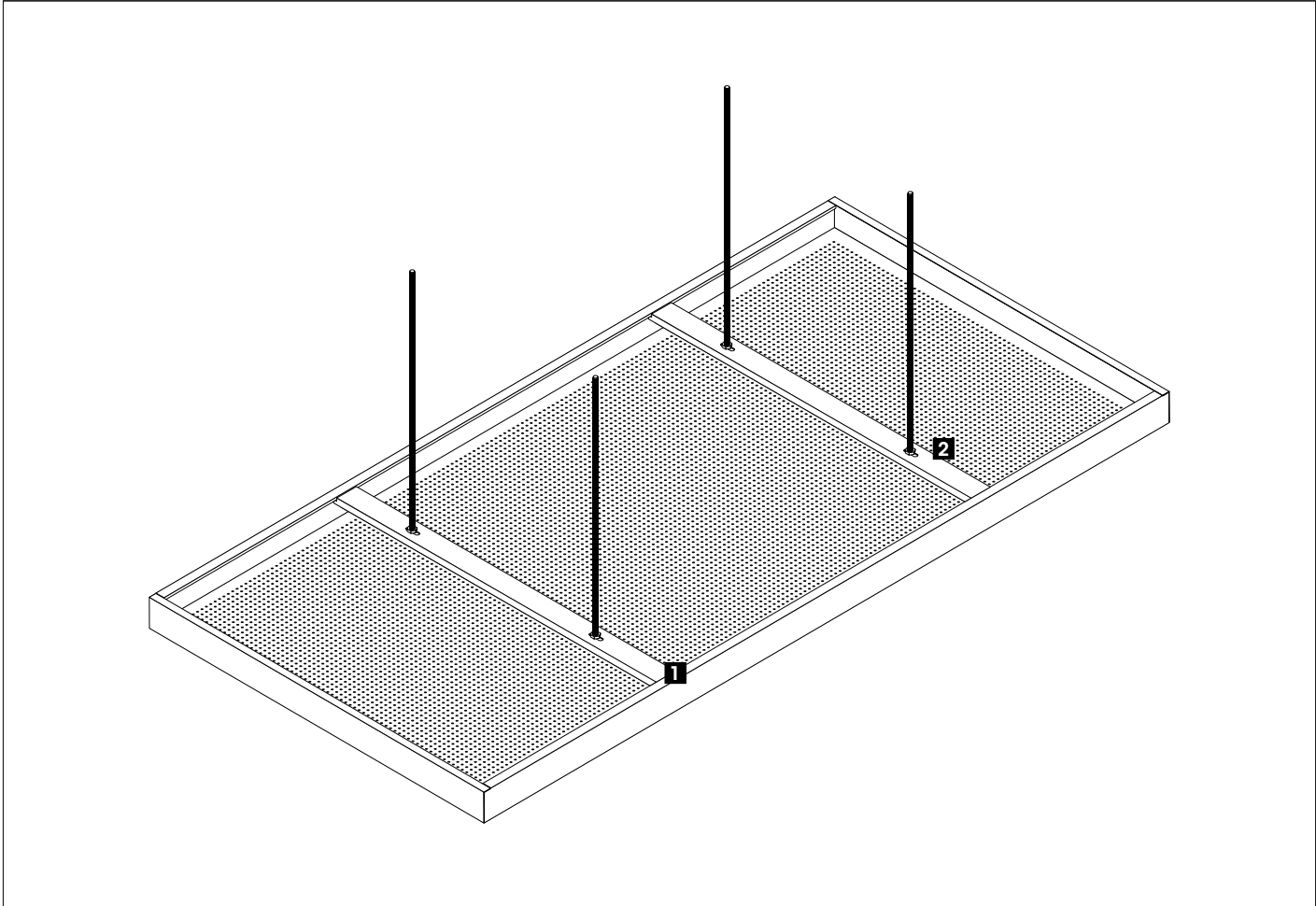

## RAFT CEILING

The durlum dur-SOLO raft ceilings excel through their floating, elegant look. They are versatile and flexible in use and are especially suited for office buildings, educational establishments, for refurbishment or organic building shapes. They can be combined optimally with thermally activated concrete ceilings. durlum's dur-SOLO is distinguished by highly flexible design options in terms of materials and surfaces up to very generous module sizes. The unobtrusive substructure with integrated transverses in the raft underline the floating character of dur-SOLO.

dur-SOLO is easy to install. Upon request, dur-SOLO is also available as hinged variant. Depending on your requirements, the system can also be supplied sound-proof or sound-absorbing or printed with graphics. The metal ceiling contributes directly to Green Building / LEED certification. durlum dur-SOLO raft ceilings fall under the general master format section 09 50 00 ceilings. When the dur-SOLO raft ceilings are supplied perforated and with sound absorption materials, they could be more specifically listed under section 09 51 33 Acoustical Metal Pan Ceilings.

### SURFACE

Galvanized steel, aluminum and stainless steel. The thickness of the material depends on the structural requirements. The galvanized steel and aluminum can be powder-coated in white matt [similar to RAL 9016] or according to customer specifications. The coating thickness is approx. 60 µm. The aluminum can also be supplied coil anodized or mirror polished. Stainless steel rectangular metal panels are available brushed or mirror polished. The powder-coated blanks can also be printed with graphics and textures of your choice.

### DIMENSIONS

#### Panel size

Length: ≤ 11'-10" [≤ 3600mm]

Width: ≤ 4'-1" [≤ 1250mm]

### SYSTEM DETAILS

#### dur-SOLO 1.1

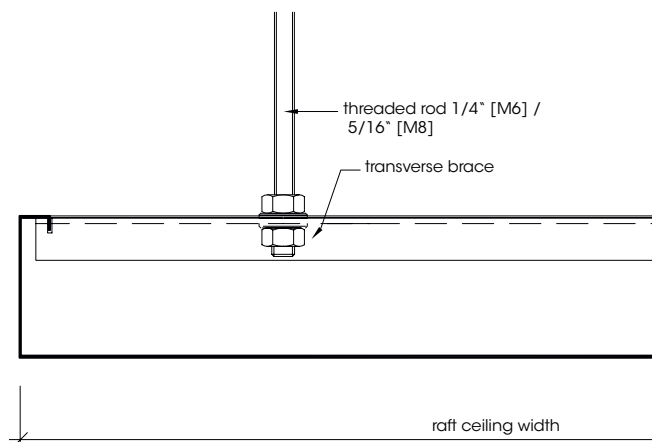

### PERFORATION AND ACOUSTICS

Metal panels are available perforated with black acoustic fleece or non-perforated. durlum offers RG L15 perforation [NRC=approx. 0.7] and RG 08 "Pico-Point" Microperforation [NRC=approx. 0.60] as standard. For other available perforations please see [www.durlum.us](http://www.durlum.us).

### FIRE PERFORMANCE

In accordance with ASTM E84 Flame Spread Index for steel is 25 or less and Smoke Developed Index for steel is 50 or less.

### GREEN BUILDING

durlum metal panels contribute directly to LEED and other GREEN BUILDING certifications. Typically applicable credits under LEED v4:

- Recycled Content – post- & pre-consumer info
- VOC Emissions – conformity with VOC requirements
- Acoustic Performance – sound absorption with acoustic fleece
- Environmental Product Declaration – available

No substances as outlined in the US Living Building v.3 Red List are internationally used.

Learn more: [greenbuilding@durlum.us](mailto:greenbuilding@durlum.us)

#### dur-SOLO 1.3

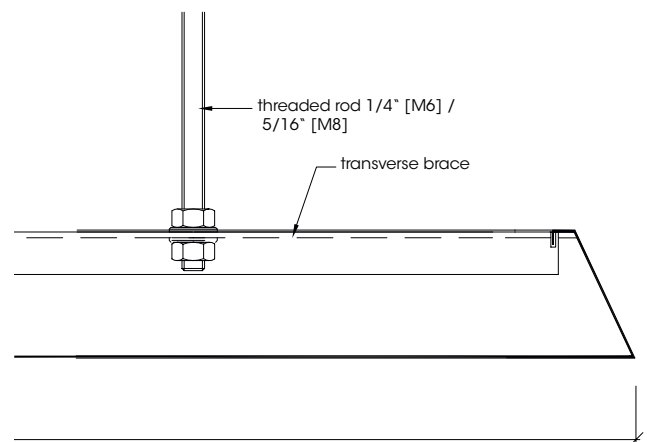

## RAFT CEILING

### PERFORATIONS

#### Micro Perforation RG-L08 „Pico Point“

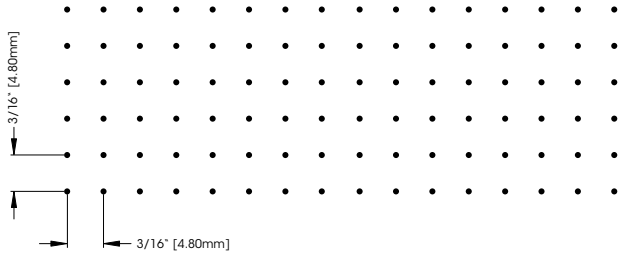

Hole diameter:  $1/32''$  [0.8mm]  
 Open area: 2.18%  
 Max. width of perforation:  $4'-2\ 1/16''$  [1272mm]  
 Max. plate width:  $4'-7\ 1/8''$  [1400mm]

#### Standard Perforation RG-L15

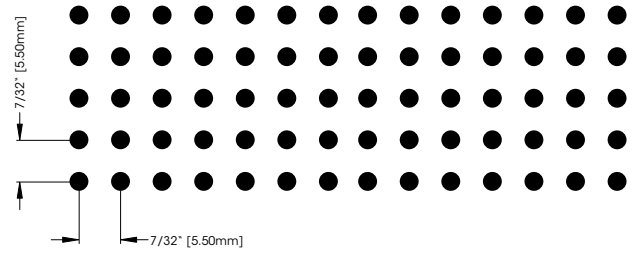

Hole diameter:  $3/32''$  [2.5mm]  
 Open area: 16.20%  
 Max. width of perforation:  $4'-8\ 3/4''$  [1441mm]  
 Max. plate width:  $4'-7\ 1/8''$  [1400mm]

### STANDARD PANEL

#### dur-SOLO 1.1

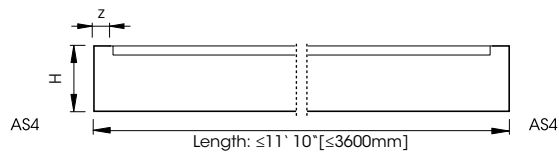

AS 4:  $H = 1\ 31/32''$  [50mm] |  $z = 15/32''$  [12mm]

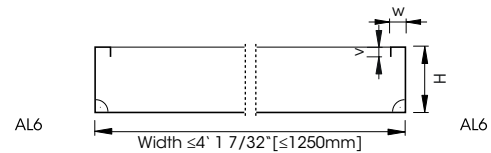

AL 6:  $H = 1\ 31/32''$  [50mm] |  $w = 19/32''$  [15mm] |  $v = 1/4'' - 13/32''$  [6-10mm]

#### dur-SOLO 1.3

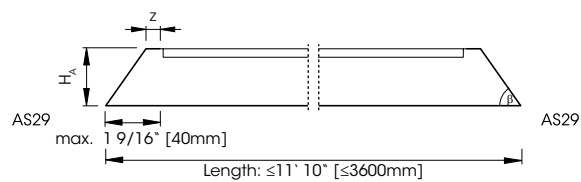

AS 29:  $H_A = 1\ 25/32''$  [45mm] |  $z = 15/32''$  [12mm] |  $\beta = 55^\circ$

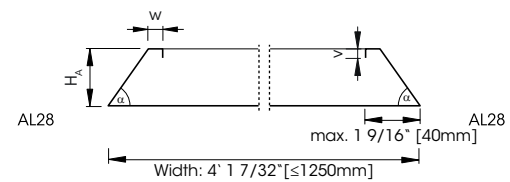

AL 28:  $H_A = 1\ 25/32''$  [45mm] |  $w = 15/32''$  [12mm] |  $v = 1/4'' - 11/32''$  [6-9mm] |  $\alpha = 55^\circ$

## RAFT CEILING

### INSTALLATION

dur-SOLO is hooked form-fitting and tension free into a special substructure, the parts of which must be approved by the manufacturer of the raft panels. Demounting without requiring tools is assured.

The substructure consists of two transverse members, each of which is rigidly suspended from the bare ceiling by two threaded rods using officially approved anchors.

#### Please note

Installation must be carried out by qualified and trained staff according to the instructions for installation. These are available as download at [www.durlum.us](http://www.durlum.us).

### TECHNICAL STANDARDS

The parts comply with DIN EN 13964 as well as ASTM C635 and ASTM E1264.

Production complies with the TAIM and CISCA guidelines and the durlum works standards and is quality controlled by the TÜV according to ISO 9001:2008 and ISO 14001:2004.

### CLEANING

As standard, durlum ceiling panels are made with an electrostatic polyester powder coating, thus providing them with a long-term finish. The powder-coated surface should always be cleaned wearing clean gloves. First clean it with a soft, dry cloth. If dirt cannot be removed by this procedure, the cloth can also be moistened, with the addition of a pH-neutral cleaner [household detergent], if necessary. Contact of the powder coating with both alkaline and acid substances must be avoided. Metallic powder coatings show a particularly sensitive reaction. Due to the risk of a change in hue or effect, for metallic coatings a suitability test must be performed.

**More information:** [durlum.us](http://durlum.us)

### MANUFACTURER



CEILING  
LIGHTING  
AMBIENCE

**durlum GmbH**  
An der Wiese 5  
79650 Schopfheim  
Germany

Phone +49.7622.3905.0  
[info@durlum.us](mailto:info@durlum.us)  
[durlum.us](http://durlum.us)

### CONTACT



**FORMGLAS SPECIALTY SOLUTIONS LTD.**  
181 Regina Road  
Vaughan, Ontario | Canada L4L 8M3

Toll Free +1.866.635.8030  
Main +1.416.635.8030  
[durlum@formglas.com](mailto:durlum@formglas.com)  
[durlum.us](http://durlum.us)